

evs/ MARS  
(Monitor and Reporting System)  
Installation and Operations Manual

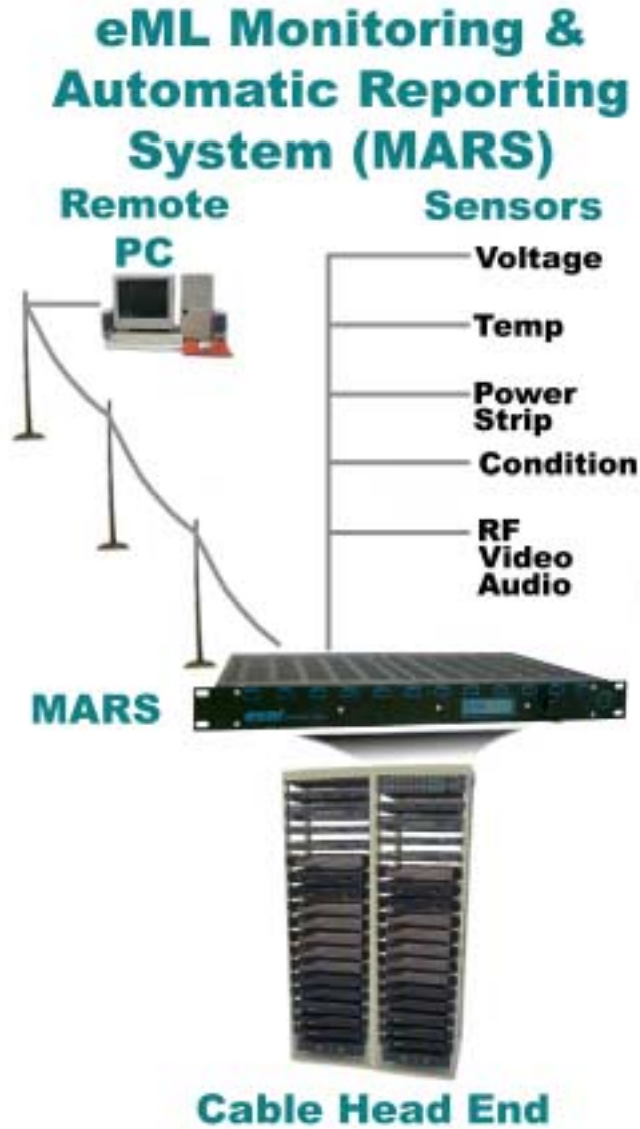

evs/

Contacting evs/:

**Address:**

Earthvision Systems Ltd  
826 57<sup>th</sup> Street East  
Saskatoon SK S7K 5Z1

**Telephone:**

Phone: (306) 931-8822 Toll-free: 800 717-8865

Mike Wohlberg, Research & Development - ext. 15  
Brent Pizzey, Research and Development - ext. 13

Facsimile: (306) 931-8787 Toll-free fax: 800 355-4576

**Website:** [www.evsl.com](http://www.evsl.com)

**Email:** [info@evsl.com](mailto:info@evsl.com) evs/ General email  
[brentp@evsl.com](mailto:brentp@evsl.com) Brent Pizzey, Research & Development  
[mikew@evsl.com](mailto:mikew@evsl.com) Mike Wohlberg, Research and Development

Printed in Canada

# Table of Contents

## 1. PC Software installation

- 1.1 System requirements
- 1.2 Software installation

## 2. MARS Hardware installation

- 2.1 Caution information
- 2.2 MARS main module installation
- 2.3 MARS external sensor(s)/devices installation
- 2.4 Serial (I2C) connection
- 2.5 RF input connection
- 2.6 Modem connection

## 3. MARS Hardware setup

- 3.1 Setup of sensor and control modules
- 3.2 RF levels
- 3.3 Configuring MARS functions
  - 3.3.1 Configuring MARS from the control panel
  - 3.3.2 Configuring MARS from the PC
- 3.4 Activating MARS

## 4. PC Software setup

- 4.1 Setting Options
- 4.2 Entering Password information
- 4.3 Opening the Data Base
- 4.4 Basic navigation of the MARS diagnostic utility
- 4.5 Creating a Site
- 4.6 Configuring the Site
- 4.7 Activating the MARS Site

## 5. MARS Specifications

# 1. PC Software Installation

## 1.1 System Requirements

- MARS was developed to operate under Windows 98, 2000, ME, XP.
- Pentium-based CPU, minimum. High speed CPU is recommended for faster performance.
- 32 MB minimum, 64 MB or higher recommended for higher performance.
- 2-button mouse.
- 1024 x 768, 256-color 17" monitor recommended.
- Modem (a hardware modem -- ISA bus modem is recommended for more reliable performance)
- Analog phone lines (PBX not recommended).

## 1.2 Software installation

- Insert MARS CD into CD-DRIVE.
- Close all other window applications currently running on your system.
- Select "**Run**" from the "**Start**" menu and browse the CD for "**setup.exe**".
- Select "**OK**" and follow the instructions within the set-up procedure. Default installation directories are recommended.

**NOTE:** MARS may contain files that are older than those currently installed on your computer. It is recommended that the newer files be kept.

# 2. MARS Hardware installation

## 2.1 Caution information

- When handling the MARS hardware it is recommended that a static strap be worn to prevent damage to components affected by static discharge.

## 2.2 MARS main module installation

The following installation procedure pre-supposes that that the operator has installed an evs/MLC chassis with either an MPS or MPSM-9 power supply.

- **Figure 1** depicts the insertion of the MARS module into an empty bay in an evsl MLC chassis. The control panel and knob are shown in **Figure 2**. (NOTE: The software version of the control panel must be 3.30 or greater--turning the knob on the MLC chassis displays the version number).
- The MARS main module is shipped with operating software but is not configured or activated by the MARS PC. In this state MARS cannot monitor any functions, neither can it dial out. The PC, though, can dial and configure the MARS module.
- The MARS module exhibits an LED status indicator (Green/Red) located at the rear of the MARS module (See **Figure 3**). RED indicates that MARS is connected and transferring data to the PC. GREEN indicates that MARS is monitoring functions.

**NOTE:** MARS cannot be accessed from the front panel while the indicator is RED.



**Figure 1: MARS module Insertion**



**Figure 2: MLC Chassis, Control panel and Knob**

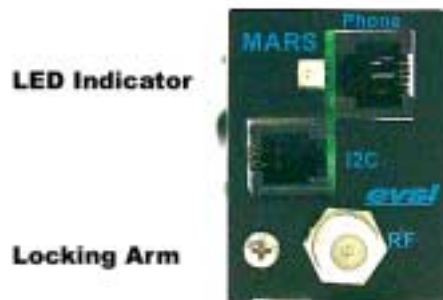

**Figure 3: MARS module rear panel**

### 2.3 MARS external sensor(s)/devices installation

- External devices, such as temperature, voltage and condition sensors, may be rack-mounted on an RP8 rack panel (See **Figure 4**). Alternately they may be mounted on a wall or ceiling using a single module L-bracket as depicted in **Figure 5**.
- Up to 8 external temperature sensor modules and 8 voltage sensor modules may be monitored by one main module.
- MARS may monitor only 1 external condition sensor. The condition sensor can sense up to 9 logic states.



**Figure 4: MARS sensors mounted on RP8 rack panel**



**Figure 5: L-bracket mount for wall or ceiling**

- Up to 8 external addressable power switches (See **Figure 8**) can be controlled by one MARS module. These devices can be mounted directly on a wall, ceiling, etc. or rack-mounted using a modified B2 panel (2U panel).



**Figure 6: MARS APS-8 (Addressable Power Strip)**

#### 2.4 Serial (I2C) connection

- MARS will monitor external as well as internal (or on-board) functions. External monitoring/controlling of functions, such as temperature, voltage and condition sensing, and power switch is accomplished via a serial I2C bus connection (See white cable connections in **Figure 4**). CATV RF, video and audio and QAM RF functions are monitored internally. All external devices are connected serially using standard flat, 4-conductor telephone cable and handset plugs crimped to the ends of the required length of cable. Each end of the cable should be inserted into each plug such that the wire colors are ordered alike when the plugs are observed in the same view. (See Appendix B for I2C cable assembly instructions.)
- Connect the devices in serial fashion using the telephone cables. Connect one of the devices (usually the one closest to the MARS main module) to the MARS module handset jack (the smaller of the two) located on its rear panel. The three external modules described above are designed with LED indicators. The indicators should be visible (Green or Red) after connecting the external modules to the MARS module.

#### 2.5 RF input connection

- Using a standard RG-59/RG-6 cable, connect the combined CATV/QAM RF output to the F-connector located on the rear panel of the MARS module as depicted in **Figure 3**. See "3.2 RF levels" for setting the RF level to the MARS input at the proper level.

#### 2.6 Modem connection

- Connect a standard telephone cable from a wall jack to the RJ11 input (the larger of the two jacks in **Figure 3**) of the MARS module.

### 3. MARS Hardware setup

#### 3.1 Setup of sensor and control modules

- The sensor modules' address can be set through an access hole (See **Figure 7**) located on one side of each mini chassis.
- The temperature and voltage sensing modules' device address must be set for MARS to properly read and configure each module. Devices of the same function set to the same

address will produce an I2C bus conflict, thus affecting other MARS operations. Insert a small, flat screwdriver into the slot of the octal selector switch and set devices of the same function to different addresses.



**Figure 7: Sensor module depicting address selector**

- The condition sensor uses the same selector switch to configure the 9th (auxiliary) input (There is only one, fixed address for this device therefore the selector switch is used for another purpose). The following options are available:

**SW0:** Aux input trips on ACTIVE HIGH signal; buzzer is DISABLED

**SW1:** Aux input trips on ACTIVE LOW signal; buzzer is DISABLED

**SW2:** Aux input trips on ACTIVE HIGH signal; buzzer is ENABLED

**SW3:** Aux input trips on ACTIVE LOW signal; buzzer is ENABLED

**SW4:** Aux input trips on ACTIVE HIGH; buzzer is DISABLED; Faults are LATCHED

**SW5:** Aux input trips on ACTIVE LOW signal; buzzer is DISABLED; Faults are LATCHED

**SW6:** Aux input trips on ACTIVE HIGH signal; buzzer is ENABLED; Faults are LATCHED

**SW7:** Aux input trips on ACTIVE LOW signal; buzzer is ENABLED; Faults are LATCHED

### 3.2 RF levels

- The RF levels of each combined CATV channel should be adjusted to a level in the range of 12 dBmV to 25 dBmV (nominally 15-20 dBmV) at the MARS input (the input may need to be padded to achieve the desired nominal input level). QAM RF levels will usually be about 7 to 10 dB lower than CATV RF levels (NOTE: The lowest RF level should not be less than a lower limit of 6 dBmV).

**NOTE:** Large RF level deviations from nominal will produce inconsistent alarm conditions. Ensure that the RF levels of all channels are within +/- 3dB of nominal at the MARS RF Input.

### 3.3 Configuring MARS functions

The operator may choose to configure MARS functions from either the eML MLC control panel or from a primary remote PC.

**Note:** Configuration from the front control panel does not configure MARS completely. It only detects the presence of select operating functions. The benefit of performing a partial configuration at the MARS location is that MARS automatically detects the presence of functions (except for QAM) which can then be uploaded to and stored in the PC.

#### 3.3.1 Configuring MARS from the control panel

Configuring MARS from the control panel consists of detecting the presence of operating functions. The following steps will direct the operator performing a partial MARS configuration:

Note: operation of the all functions of any module in the MLC (Modular Line Chassis) is accomplished by: **Rotating** the MLC control knob to highlight a selection or adjust a parameter, and **Pushing** the MLC control knob to “select” or “store” it.

- Select the bay in which MARS is inserted.
- Select "Channels/Det CATV" for MARS to detect all valid CATV channels. A message will appear on the control panel LCD informing the operator that channels are being detected (push the control knob at any time to stop auto-detection). After completing the process, MARS displays the status of detected channels (hi-lighted) over several screens. Turn the knob to view subsequent screens. Push the control knob to exit the "View screen". Select "Go Back" to return to the previous menu. The channel status can be viewed at any time by selecting "Channels/CATV".
- Select "Channels/QAM" to view configured QAM channels. QAM channels can only be viewed from the MLC control panel. They are configured from the MARS PC.

**NOTE:** A channel will not be entered as part of the auto-detect configuration if any one of RF, video or audio is absent. The channel can however be entered from a primary remote PC

- Select "Temp/Detect" to detect all valid temperature modules. A momentary lapse will take place prior to displaying the temperature status results. Rotating the control knob selects the next detected temperature module (hi-lighted). The current temperature and temperature trip value for each detected temperature module can be read at the bottom of the screen. Push the control knob to exit the "View screen". Select "Go Back" to return to the previous menu. The temperature status can be viewed at any time by selecting "Temp/View".
- Select "Voltage/Detect" to detect all valid voltage modules. A momentary lapse will take place prior to displaying the voltage status results. Rotating the control knob selects the next detected voltage module (hi-lighted). The current status of each module is displayed at the bottom of the screen. "On" indicates that the

main or auxiliary function is detected and operating. "Off" indicates that the main or auxiliary function is detected, but the voltage is removed from that sensor. A "---" indicates that the main or auxiliary function is not detected. Push the control knob to exit the "View screen". Select "Go Back" to return to the previous menu. The voltage status can be viewed at any time by selecting "Voltage/View".

**NOTE:** AC/DC voltage must be available at the AC modules for MARS to detect the modules (See spec sheet for voltage range).

- Select "Cond'n/Detect" for MARS to detect valid inputs to the condition sensor. A momentary lapse will take place prior to displaying the condition status results. Rotating the knob selects the next input and displays the alarm status (highlighted). The status of the selected input is "True" if the input is valid and "False" if invalid. The auxiliary input is viewed as a separate entity at the bottom of the screen. It will display "---" if not detected. Push the control knob to exit the "View screen". Select "Go Back" to return to the previous menu. The condition sensor status can be viewed at any time by selecting "Cond'n/View".

**NOTE:** A valid logic-level input must be present for MARS to detect the condition module inputs.

- Proceed to "PC Software setup" to complete MARS configuration.

### 3.3.2 Configuring MARS from the PC

- To configure MARS from the PC, select "SYSTEM" from the MLC control panel and ensure that MARS is "ENABLED".
- Proceed to "PC Software setup" to complete MARS configuration.

## 4. PC Software setup

PC software must be setup to enable MARS configuration. Follow the subsequent procedures for proper PC setup.

### 4.1 Setting Options

- A minimal options configuration is required before the PC can communicate with MARS. Select "Options..." from the Tools menu.
- Under the "General" tab select "Enable auto-configuration from MARS to PC" only if the PC is to be updated with the configuration received from MARS (see: "3.3.1 Configuring MARS from the control panel").
- Under the "General" tab browse the default database path required to open the database.
- Under the "Modem Settings" tab click the radio button under "Port" that associates with your computer's modem port setting.
- Since all other features under the "General" and "Modem Settings" tab are optional, select "Save" to store the current options configuration.
- Under "Mars Security" a user and configuration password must be entered before MARS operations can begin. Password(s) must be cleared prior to entering new passwords, otherwise the operator must know the current password(s). See "4.2 Entering Password information" to clear the passwords.

- The user password is used to open the database. Leaving "Old Password" blank if the password is cleared or entering the "Old Password" if known, enter the "New Password" and "Confirm Password" with a minimum of four alphanumeric characters and a maximum of 10.

**Note:** Alpha characters are NOT case sensitive.

- The configuration password is used to access all the functions under "Tools" except for "Options" and "Maintenance". The tools functions cannot be accessed, though, until a user password is entered. Leaving "Old Password" blank if the password is cleared or entering the "Old Password" if known, enter the "New Password" and "Confirm Password" with a minimum of four alphanumeric characters and a maximum of 10.
- After entering the password(s), select Save to store the new passwords.

#### 4.2 Entering Password information

- Before a new password can be entered, there must be either a current, valid password or the password must be cleared. If a valid password currently exists, then follow the instructions under "4.1 Setting Options" to change the password(s).
- To clear the password(s), select "Tools/Password Administration".
- After a window appears, the user must enter the product ID and click "Submit" to enable the check boxes for clearing password(s). Check either one or both boxes, and then select "OK". The password(s) will be cleared after selecting "Yes" to the subsequent dialogues.
- See "4.1 Setting Options" for instructions to enter a new password.

#### 4.3 Opening the Data Base

- After the user password is configured and the default database path is set in "Options" the operator can open the database.
- Select "File/Open Database" from the tools menu or select a "recent file" from the "Files" menu.
- Enter the USER password and press "ENTER" or select "OK".
- The file name will be appended to the "MARS Diagnostic Utility" title located on the top bar. If the database contains status information, the screen will display the results of the information, otherwise the screen will be blank.

#### 4.4 Basic navigation of the MARS Diagnostic Utility (MDU)

To familiarize the operator with MARS diagnostic screen navigation, a brief description of the controls follows:

- The Region can be selected by clicking on the combo box at the upper left corner of the MDU. Selecting the region will cause the Site field to be filled.
- A Site is selected by clicking a site name in the Site list box. Selecting a Site causes the remainder of the screen to be filled with site status information.
- When a site is selected the "Answer" and "Dial MARS" buttons are enabled. Selecting the "Answer" button allows the PC to receive data from the MARS Sites. Selecting "Dial MARS" invokes a dial-up connection of the selected Site.

- The main screen is divided up into several sections. The MARS Power Status, located at the upper left of the screen, displays the DC power status to the MARS module as well as the date and time of the current MARS status.
- Voltage status (main and auxiliary) is displayed at the top of the screen, while temperature is displayed near the bottom of the screen.

**NOTE:** By moving the cursor over the temperature display boxes, a ToolTip will appear displaying the current temperature trip point.

- The center section displays the RVA (RF, Video, and Audio) results of detected CATV channels. Within the same section the status QAM channels can also be displayed. Only the "R" of "R V A" is used while status of "V A" is replaced with a "QAM" label.
- To display the results of the remainder of the channels select the "Toggle Status Page" button located at the bottom right side of the Channel Status screen.
- In addition to RVA, the second status-page displays the "Alarm Sensor" and battery status.
- Next to the Next Status Page" button is a display of the current status record and the total number of status records for the selected site. Clicking the arrows on either side of the display retrieves subsequent or previous status data.

#### 4.5 Creating a Site

- Prior to configuring a MARS Site the user must enter a minimal of information in the Region and Site windows. Select "Tools/DataBase Manager/Region Manager" from the tools menu. Enter the CONFIGURATION password and press ENTER or select "OK". When the Region Manager window appears, enter a region name and click "Add". Select "Close" to exit the Region Manager.
- Select "Tools/DataBase Manager/Site Manager" from the Tools menu. Enter the CONFIGURATION password and press ENTER or select "OK". When the Site Manager window appears, enter a Site name and select an associated region from the Region List.
- Enter the Site Phone and PC Phone1. The Site Phone is the phone number dialed from the PC to access the site. PC Phone1 is required by the MARS module to dial the PC. Check the "Enabled" box next to PC Phone1. (These phone number have no formatting--whatever the user enters will be dialed. A maximum of 30 numbers can be entered including commas; each comma representing a 2-second delay--can be used for dialing 9).
- Select "Add" then "Close" to exit the site manager.
- The Region Name and the Site within that region now appear on the main screen.

#### 4.6 Configuring the Site

- Once a Region and Site have been created the user can open the configuration window to enter the basic information required to configure a MARS Site.
- Select "Tools/MARS Configuration" from the tool bar. Enter the CONFIGURATION password and press ENTER or select "OK". The MARS configuration window appears.

- Select the Region and Site you wish to configure. The MARS Site can be configured in one of two ways. The first (allowing MARS to detect the presence of functions) was discussed in "3.3.1 Configuring MARS from the control panel". To configure MARS from the PC, perform the following:
  - In the "MARS module--Channel monitoring configuration" frame, select the CATV channels that MARS should monitor by clicking on the "En" box beside each channel. The function of the next two boxes (RVA and Aud) is not required for minimal setup.
  - In the "Sensors" frame, select the voltage and temperature modules and condition inputs that MARS should monitor by clicking the boxes beside each number. The numbers beside the boxes represent the selected address of each voltage and temperature module (discussed earlier in "3.1 Setup of sensor modules"). Each number beside each box of the condition sensor represents a single input.
  - Enter the temperature trip points a few degrees higher than the anticipated temperature of each temperature module.
- Enter "200" in the "RF Threshold" text box. (200 is a "level" required for a RF input of about 15 dBmV). A fault will be detected when then RF-level drops approximately 10 dB. See Appendix A for a complete graph of values.
- Enter "255" into the "Max Fault Tx" text box. A number from 1 to 255 may be entered. When MARS dials the number of faults or restorations indicated in the text box, the PC will return information to MARS to inhibit further calls for the remainder of the current day. MARS will reset this status at midnight. This is useful if you want to limit the number of calls in a day.
- Enter an "Audio Delay" of 6. A number from 1 to 6 may be entered. With lower numbers MARS to be more sensitive to intermittent audio lapses.
- Click "Next Page" to advance to the QAM configuration screen. Select the QAM channels that MARS should monitor by clicking on the "En" box beside each channel. Note that if a CATV channel is already configured for this channel, QAM cannot be configured. Alternately if QAM is previously configured then CATV cannot be configured for this channel.
- Enter "225" in the "QAM Threshold" text box (225 is a "level" required for a RF input of about 8 dBmV). A QAM fault will be detected when the RF-level drops approximately 10 dB. See Appendix A for a complete graph of values.
- Click "Next Page" to advance to the Power Strip configuration screen. This screen allows the user to select up to 8 Power Strips. Each Power Strip can be configured to individually switch 117 VAC power to each of its 8 receptacles. Enable a receptacle by clicking the "En" button associated with that receptacle (the button will turn GREEN). Additionally, each receptacle can be cycled for a predetermined time. Clicking the "Sw" button associated with the receptacle to be cycled and typing in a value between 1 and 255 seconds in the "Sw Delay" text box will configure the Power Strip to momentarily remove power from that receptacle for the time entered. (NOTE: After the data is sent to MARS, all buttons under the "Sw" heading will automatically be cleared. This ensures that the power is cycled only once for each call).
- The "Write Site Code" and "Disable Site Code" will be discussed in the next section.
- Select "Save" to store the selected information in the database.

#### 4.7 Activating the MARS Site

- When a site is created it is automatically assigned a "Site Code" permanently stored in the database. The site code cannot be altered. The Site can be deleted, though, and a new site under the same name can be created with a different site code. The same site code can never be duplicated.
- Select the MARS site for activation.
- Open the configuration window and check the "Write Site Code" check box, then select "Close" to exit the configuration window. Note that "Write Site Code" will appear in RED in the "Site Fault Status" frame on the main MARS screen. The label will disappear after the site code has been sent to MARS.
- Select "Dial MARS" in the "Control" frame. The status line under the control box will reflect the MARS communication status. After connecting, the status line will display "Connected".
- The user can watch the status window for the message "Site Code Written" to ensure that the site code has been written to the MARS site. After communication is complete, the status window displays "Waiting for connection".

**Note:** If "Site Code Written" does not appear on the status window then the "Write Site Code" box in the configuration window may have to be checked again prior to subsequent dialing for activation purposes. The check box automatically clears after each dial to prevent accidental re-configuration of the MARS.

- Activating the site does not update the database with the next status record. The MARS site must be dialed a to receive the record. Retrieving a status record will indicate that MARS is configured correctly.
- The MARS site now retains a basic configuration. Testing communication from MARS may be performed by (for instance) removing voltage from the power sensor module. When the data is received by the PC, the display box next to the selected site will be RED indicating a fault--an "\*" will also be inserted before the Region Name in the Region Combo box. (Note: the box next to the region will also be RED indicating that there is a fault in the selected region).
- MARS is now ready for normal operation.

## 5. MARS Specifications

Main Module Monitoring CATV parameters	RF, Video and Audio on Channels 2 to 125
Battery Backup Type	6-volt (nominal) NiCAD pack
Charging	Continuous
Duration	30 to 90 minutes
Sensing Devices Temperature	Maximum of 8 devices (-55 to 100 degrees C)
Power	Maximum of 8 devices (6 to 130 VAC/VDC)
Condition	Maximum of 1 device (9 inputs, 1 auxiliary output)
Control	Via front panel and remote PC.
DC Power Input	+9.2 VDC, 500 ma
Operating Temperature Main Module	0 to 40 degrees C (32 to 104 degrees F)
Sensing Devices	0 to 50 degrees C (except for temperature module)
Mounting Main Module	MLC* chassis, occupies one of 12 bays
Sensing Devices	Panel mount or wall bracket mount

### Communication

Remote Analogue Telephone Modem

**Sensing Devices I2C Bus\*\***

### Dimensions

Main Module	1.75''(h) x 1.33''(w) x 11''(d)	(4.45 x 3.38 x 27.94 cm)
MLC Chassis *	1.75''(h) x 19''(w) x 12.25''(d)	(4.45 x 48.26 x 31.12 cm)

### Connections

RF input	F-Connector
Telephone	RJ-11 jack
I2C Bus **	Handset jack

\* MLC: Modular Line Chassis of *evs/*'s *eML* Family

\*\* I2C: Inter-Integrated Circuit (a 2-wire bus specification developed by Philips Semiconductor)

Graph of MARS RF threshold values for CATV

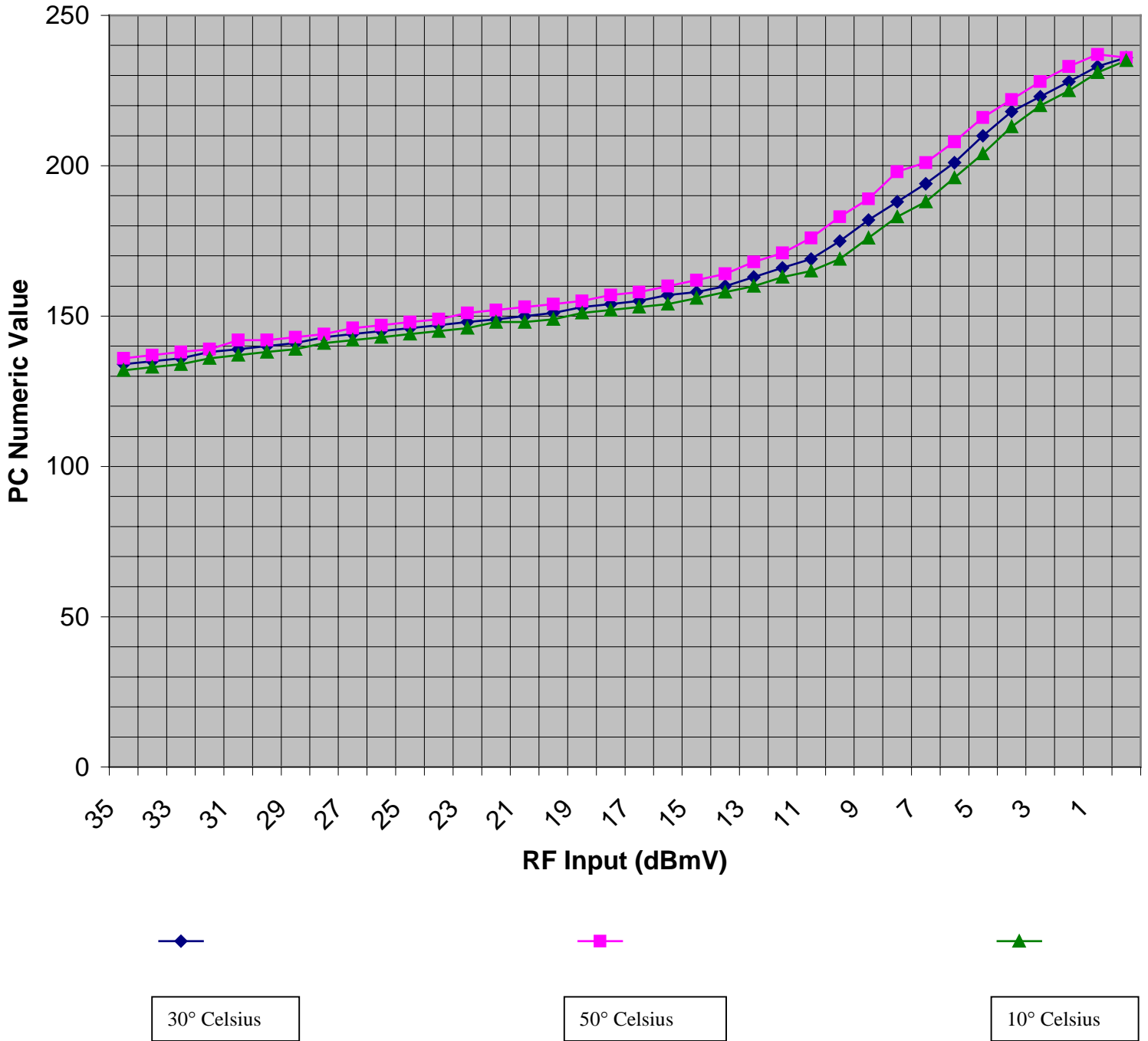

**Graph of MARS RF threshold values for QAM**

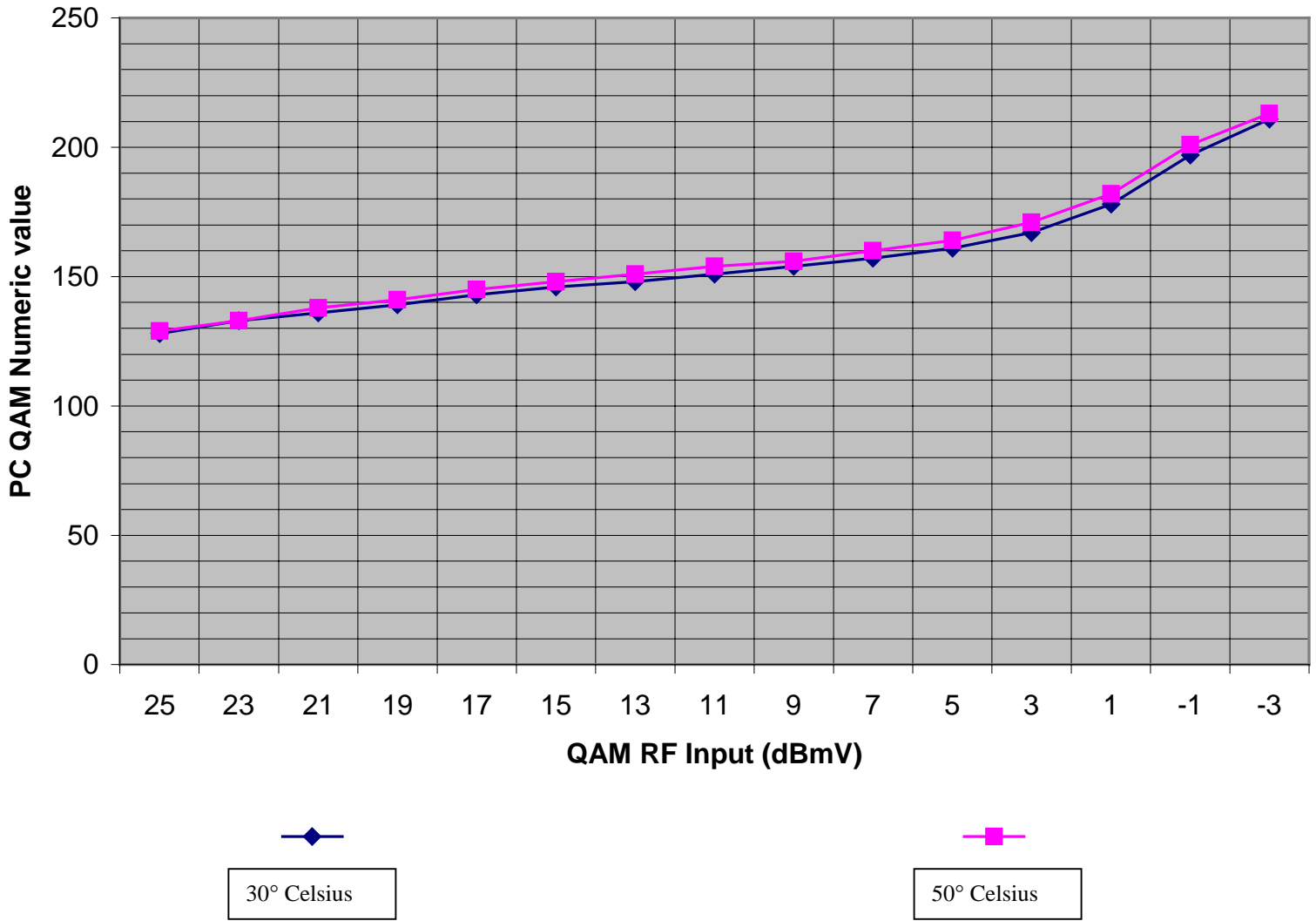

## Appendix B - I2C cable assembly instructions

### Cable Assembly for I2C Bus

#### Parts List:

- a) Handset Plugs
- b) Telephone cord(standard 4-wire)

#### Assembly:

1. Using conventional tool, connect handset plugs to telephone cord ensuring that the wires are ordered the same on each handset plug.  
(See figure 1, below)

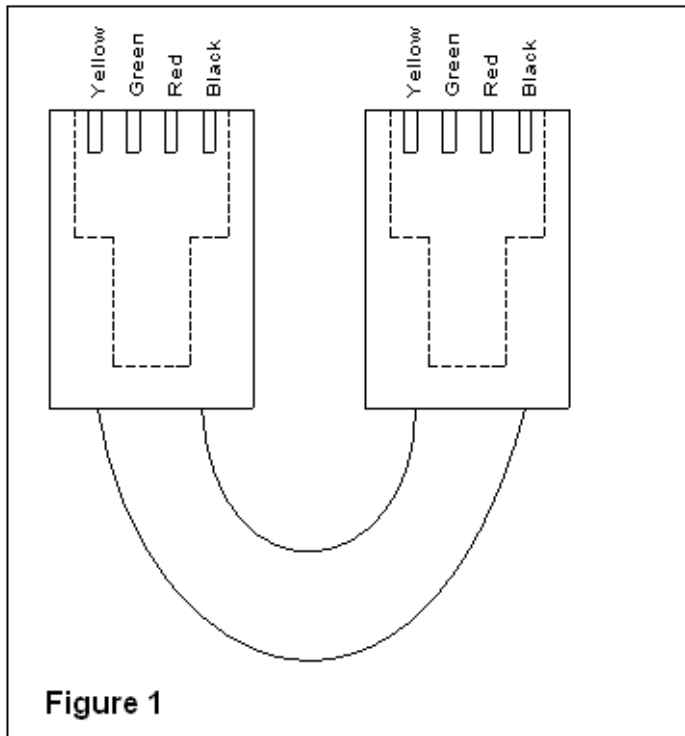

#### Note:

Dotted lines indicate hidden lines.  
The hand set locking tab is viewed on the under side.